

MYLAR

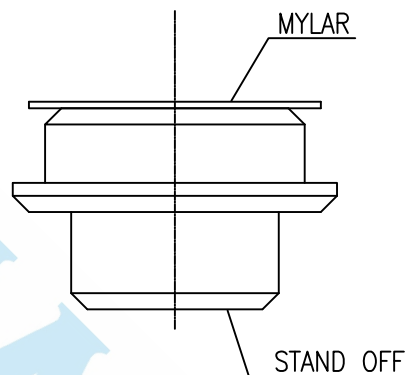

ASSEMBLY

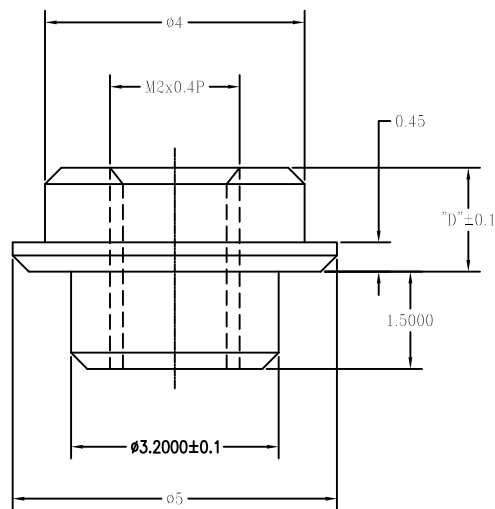

STAND OFF

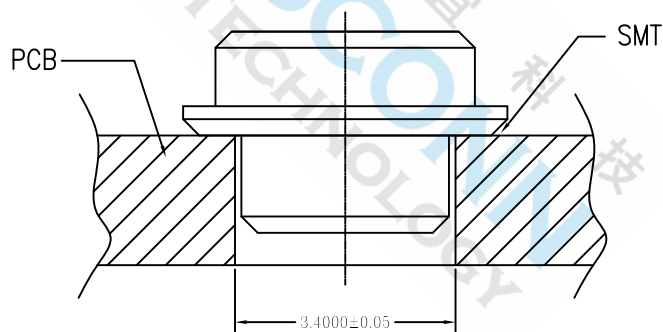

PCB Layout Recommended

備註：

1. 材質：
螺柱：C3604
MYLAR：POLYIMIDE FILM
2. 電鍍規格：
螺柱：Sn 100u"(min)
3. 毛邊：0.05 MAX.
4. 一般公差：± 0.1mm, ± 2°

P/N	D
WMPE-STAND OFF-40	1.6
WMPE-STAND OFF-57	3.3
WMPE-STAND OFF-90	6.6
WMPE-STAND OFF-92	6.8

DIMENSIONS TOLERANCE

METRIC

.0 = ± 0.30
.00 = ± 0.20
.000 = ± 0.10
ANG. = ± 2°

單位(UNITS)

MM

處理(FINISH)

SEE NOTE

審核(CH'K)

Calvin

圖名(NAME)

MINI PCI-E STAND OFF

WISCONN Technology Co., Ltd

Tel: 02-2790-1979

Fax: 02-2790-1569

數量(QTY)

N/A

繪圖(DRAW)

Johnson

核准(APP'D)

Selena

料號(PART NUMBER)

WMPE-STAND OFF-xx

圖號(DRAW NUMBER)

T027

圖檔(FILE NAME .DWG)

比例
(SCALE)

1/1

圖紙
(SIZE)

A4

頁次
(SHEET)

1

版次
(REV.)

A

材料(MTL)

SEE NOTE

設計(DE'N)

Mike

日期(DATE)

AUG.12.2016

比例
(SCALE)

1/1

圖紙
(SIZE)

A4

頁次
(SHEET)

1

版次
(REV.)

A

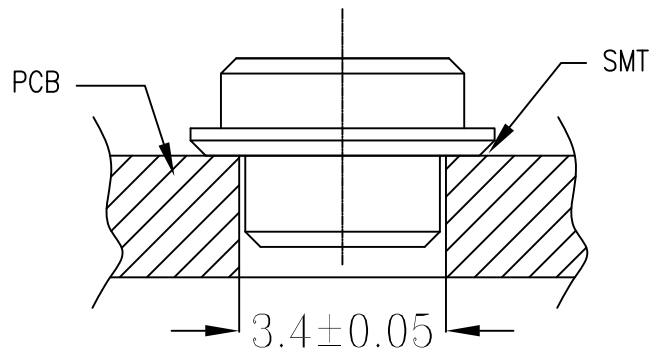

PCB Layout Recommended

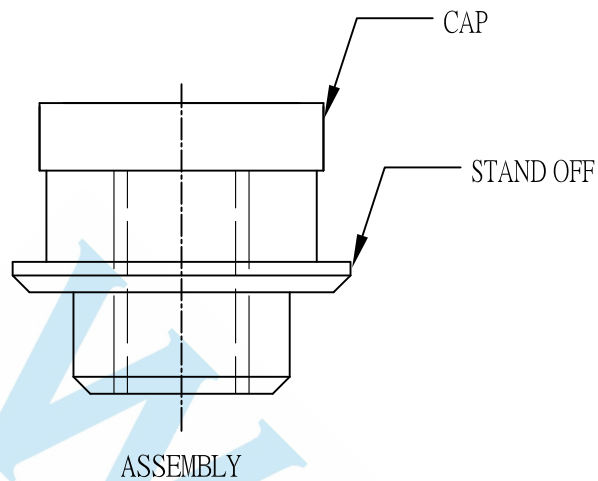

ASSEMBLY

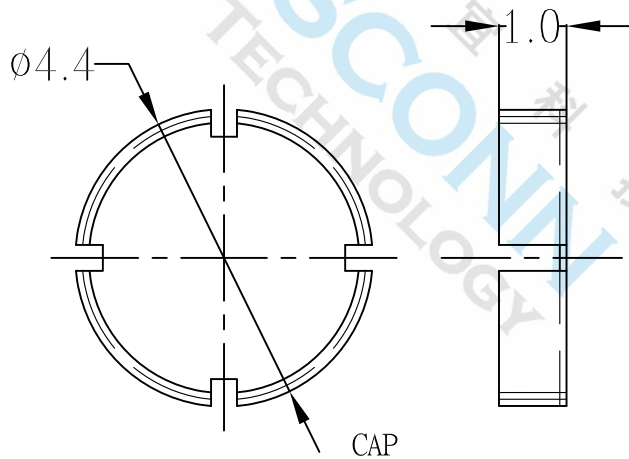
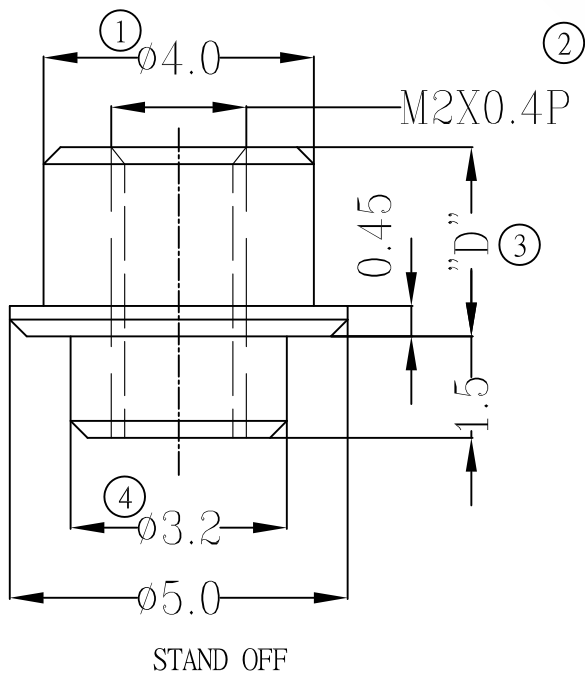

備註Note :

1. 材質
螺柱: C3604
吸盤蓋: SUS301
2. 電鍍規格
螺柱: Sn 100u"(min)
3. 毛邊 : 0.05 MAX.
4. 一般公差: $\pm 0.1, \pm 2^\circ$.

P/N	D
WMPE-STAND OFF-52	2.8
WMPE-STAND OFF-56	3.2
WMPE-STAND OFF-80	5.6

DIMENSIONS TOLERANCE

METRIC

.0 = ± 0.30
.00 = ± 0.20
.000 = ± 0.10
ANG. = $\pm 2^\circ$

單位(UNITS)	MM	處理(FINISH)	SEE NOTE	審核(CH'K)	Calvin	圖名(NAME)
數量(QT'Y)	N/A	繪圖(DRAW)	Johnson	核准(APP'D)	Selena	MINI PCI-E STAND OFF
材料(MT'L)	SEE NOTE	設計(DE'N)	Mike	日期 (DATE)	AUG.12.2016	料號(PART NUMBER) WMPE-STAND OFF-xx
						圖號(DRAW NUMBER) T027
						圖檔(FILE NAME .DWG)

WISCONN Technology Co., Ltd
Tel: 02-2790-1979 Fax: 02-2790-1569

比例 (SCALE)	圖紙 (SIZE)	頁次 (SHEET)	版次 (REV.)
1/1	A4	1	A

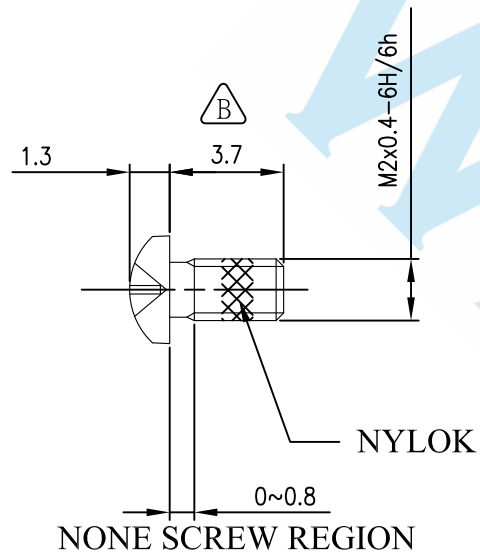
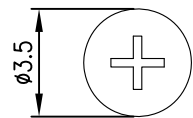

NOTES:

1. MATERIAL: COPPER ALLOY
2. PLATING: NICKEL
3. SCREW TORQUE: 2.04 KG-CM (MAX.)
 FIRST STRIP: 0.20 KG-CM (MIN.)
 FIFTH STRIP: 0.10 KG-CM (MIN.)
4. GENERAL TOLERANCE: ± 0.3
5. PACKING: 1000 PCS/PE BAG

DIMENSIONS TOLERANCE METRIC .0 = ± 0.30 .00 = ± 0.20 .000 = ± 0.10 ANG. = $\pm 2^\circ$	單位(UNITS)	MM	處理(FINISH)	SEE NOTE	審核(CH'K)	Calvin	圖名(NAME)		WISCONN Technology Co., Ltd Tel: 02-2742-1798 Fax: 02-2742-1898					
	數量(QTY)	N/A	繪圖(DRAW)	Johnson	核准(APP'D)	Selena	MINI PCI-E SCREW							
	料號(PART NUMBER)	WMPE-SCREW-3.7	圖號(DRAW NUMBER)	T027	圖檔(FILE NAME .DWG)		比例(SCALE)	1/1	圖紙(SIZE)	A4	頁次(SHEET)	1	版次(REV.)	A
	材料(MTL)	SEE NOTE	設計(DE'N)	Mike	日期(DATE)	OCT.15.2007								